

Indication modules



→ LED-indication modules

- › Compact module in a 96 x 96 mm housing for panel mounting
- › 8 or 16 channels with exchangeable LED's
- › Several alarm voltages in a range from 24 V up to 230 V
- › Integrated lamp test push button
- › Collective report optional
- › Front panel marking: transparent window for slide-in labels
- › Low built-in depth

→ [Datasheet](#)



→ Technical description

The LAB-indicators are compact modules for panel mounting, with 8 or 16 channels and integrated lamp test push buttons. In the basic version (without collective report) the connection of an additional external test button, is possible.

The devices are equipped with LED's in red or green colour, mounted on plug base, which are interchangeable and different LED colours can be installed after removing the front panel. Other colours are available in a set of 10 LED's per colour.

Note: Always use "high efficiency" LED types!

Attention: Disconnect supply voltage!

	Bezeichnung	Ausrüstung
	LAB 08-1	8 channels in NO design LED colour green external lamp test
	LAB 08-1M	8 channels in NO design LED colour red Collective report *
	LAB 08-1MR	8 channels in NC design ** LED colour red Collective report *
	LAB 08-1IMR	8 channels in NC design ** LED colour red Collective report inverted
	LAB 16-1	16 channels in NO design LED colour green external lamp test
	LAB 16-1M	16 channels in NO design LED colour red Collective report *
	LAB 16-1MR	16 channels in NC design ** LED colour red Collective Report *
	LAB 16-1IMR	16 channels in NC design ** LED colour red Collective report inverted

* Each discrete alarm can be selected by programming jumpers to assign on collective report. In standard the collective report is a NO contact on request it can be realized as a NC contact. An inverting function is also available.

** When the collective report contact is wired as NC, then not used inputs have to be connected on L1 or +.



Type*	Article No.*	Collective report	Design of collective report	Level of signal input	LED	Contact of collective report if	
						U _g present	U _g break down
LAB ..-1/24 LAB ..-1/48 LAB ..-1/60 LAB ..-1/110 LAB ..-1/125 LAB ..-1/220 LAB ..-1/230	21LAB..1011 21LAB..10D2 21LAB..10E3 21LAB..10F5 21LAB..10H5 21LAB..10J7 21LAB..10U7	not available	-	Low High	off active	not available	
LAB ..-1M/24 LAB ..-1M/48 LAB ..-1M/60 LAB ..-1M/110 LAB ..-1M/125 LAB ..-1M/220 LAB ..-1M/230	21LAB..1M11 21LAB..1MD2 21LAB..1ME3 21LAB..1MF5 21LAB..1MH5 21LAB..1MJ7 21LAB..1MU7	normal	Normally open	Low High	off active	open closed	open open
LAB ..-1MR/24 LAB ..-1MR/220 LAB ..-1MR/230	21LAB..1MR1 21LAB..1MRJ 21LAB..1MRU	normal	Normally open	Low High	active off	closed open	open open
LAB ..-1IMR/24 LAB ..-1IMR/60 LAB ..-1IMR/110 LAB ..-1IMR/125 LAB ..-1IMR/220 LAB ..-1IMR/230	21LAB..1IMR1 21LAB..1IMRE 21LAB..1IMRF 21LAB..1IMRH 21LAB..1IMRJ 21LAB..1IMRU	inverted	Normally open	Low High	active off	open closed	open open

In the following table the states of the LEDs and of the collective report are shown in dependency of the device type and the states present at the signal inputs.

* .. is used as a wildcard for 08 or 16

➔ Technical data

Type	LAB 08-1/24	LAB 08-1/48	LAB 08-1/60	LAB 08-1/110	LAB 08-1/125	LAB 08-1/220	LAB 08-1/230
Article No.	21LAB081011	21LAB0810D2	21LAB0810E3	21LAB0810F5	21LAB0810H5	21LAB0810J7	21LAB0810U7
Supply voltage	24 V AC/DC ± 20 % max. 1.5 W	48 V DC ± 20 % max. 3 W	60 V DC ± 20 % max. 3.5 W	110 V DC ± 20 % max. 3.5 W	125 V DC ± 20 % max. 3.5 W	220 V DC ± 20 % max. 5.5 W	230 V AC +10 / -15 % max. 5.5 W
Power consumption	24 V AC/DC ± 20 % approx. 6 mA	48 V AC/DC ± 20 % approx. 4 mA	60 V AC/DC ± 20 % approx. 4 mA	110 V DC ± 20 % approx. 4 mA	125 V DC ± 20 % approx. 4 mA	220 V DC ± 20 % approx. 4 mA	230 V AC/DC ± 20 % approx. 4 mA
max. input current per signal input	approx. 6 mA	approx. 4 mA	approx. 4 mA	approx. 4 mA	approx. 4 mA	approx. 4 mA	approx. 4 mA
Operating and ambient temperature without condensation	-20°C...+60°C	-20°C...+50°C	-20°C...+50°C	-20°C...+50°C	-20°C...+50°C	-20°C...+50°C	-20°C...+50°C

Type	LAB 16-1/24	LAB 16-1/48	LAB 16-1/60	LAB 16-1/110	LAB 16-1/125	LAB 16-1/220	LAB 16-1/230
Article No.	21LAB161011	21LAB1610D2	21LAB1610E3	21LAB1610F5	21LAB1610H5	21LAB1610J7	21LAB1610U7
Supply voltage	24 V AC/DC ± 20 % max. 2.5 W	48 V DC ± 20 % max. 5 W	60 V DC ± 20 % max. 6 W	110 V DC ± 20 % max. 6 W	125 V DC ± 20 % max. 6 W	220 V DC ± 20 % max. 10 W	230 V AC +10 / -15 % max. 10 W
Power consumption	24 V AC/DC ± 20 % approx. 6 mA	48 V AC/DC ± 20 % approx. 4 mA	60 V AC/DC ± 20 % approx. 4 mA	110 V DC ± 20 % approx. 4 mA	125 V DC ± 20 % approx. 4 mA	220 V DC ± 20 % approx. 4 mA	230 V AC/DC ± 20 % approx. 4 mA
max. input current per signal input	approx. 6 mA	approx. 4 mA	approx. 4 mA	approx. 4 mA	approx. 4 mA	approx. 4 mA	approx. 4 mA
Operating and ambient temperature without condensation	-20°C...+60°C	-20°C...+50°C	-20°C...+50°C	-20°C...+50°C	-20°C...+50°C	-20°C...+50°C	-20°C...+50°C



Type	LAB 08-1M/24 LAB 08-1MR/24 LAB 08-1IMR/24	LAB 08-1M/48	LAB 08-1M/60 LAB 08-1IMR/60	LAB 08-1M/110 LAB 08-1IMR/110	LAB 08-1M/125 LAB 08-1IMR/125	LAB 08-1M/220 LAB 08-1IMR/220 LAB 08-1IMR/220	LAB 08-1M/230 LAB 08-1MR/230 LAB 08-1MR/230
Article No.	21LAB081M11 21LAB081MR1 21LAB081IMR1	21LAB081MD2	21LAB081ME3 21LAB081IMRE	21LAB081MF5 21LAB081IMRF	21LAB081MH5 21LAB081IMRH	21LAB081MJ7 21LAB081MRJ 21LAB081IMRJ	21LAB081MU7 21LAB081RMU 21LAB081MRU
Supply voltage	24 V AC/DC ± 20 % max. 2.0 W	48 V DC ± 20 % max. 3.5 W	60 V DC ± 20 % max. 4.0 W	110 V DC ± 20 % max. 4.0 W	125 V DC ± 20 % max. 4.0 W	220 V DC ± 20 % max. 6.5 W	230 V AC +10 / -15 % max. 6.5 W
Power consumption	24 V AC/DC ± 20 %	48 V AC/DC ± 20 %	60 V AC/DC ± 20 %	110 V DC ± 20 %	125 V DC ± 20 %	220 V DC ± 20 %	230 V AC/DC ± 20 %
max. input current per signal input	approx. 6 mA	approx. 4 mA	approx. 4 mA	approx. 4 mA	approx. 4 mA	approx. 4 mA	approx. 4 mA
Operating and ambient temperature without condensation	-20°C ... +60°C	-20°C ... 50°C	-20°C ... +50°C	-20°C...+50°C	-20°C...+50°C	-20°C...+50°C	-20°C...+50°C

Type	LAB 16-1M/24 LAB 16-1MR/24 LAB 16-1IMR/24	LAB 16-1M/48	LAB 16-1M/60 LAB 16-1IMR/60	LAB 16-1M/110 LAB 16-1IMR/110	LAB 16-1M/125 LAB 16-1IMR/125	LAB 16-1M/220 LAB 16-1IMR/220 LAB 16-1IMR/220	LAB 16-1M/230 LAB 16-1MR/230 LAB 16-1MR/230
Article No.	21LAB161M11 21LAB161MR1 21LAB161IMR1	21LAB161MD2	21LAB161ME3 21LAB161IMRE	21LAB161MF5 21LAB161IMRF	21LAB161MH5 21LAB161IMRH	21LAB161MJ7 21LAB161MRJ 21LAB161IMRJ	21LAB161MU7 21LAB161MRU 21LAB161MRU
Supply voltage	24 V AC/DC ± 20 % max. 3.5 W	48 V DC ± 20 % max. 6 W	60 V DC ± 20 % max. 7 W	110 V DC ± 20 % max. 7 W	125 V DC ± 20 % max. 7 W	220 V DC ± 20 % max. 11 W	230 V AC +10 / -15 % max. 11 W
Power consumption	24 V AC/DC ± 20 %	48 V AC/DC ± 20 %	60 V AC/DC ± 20 %	110 V AC/DC ± 20 %	125 V DC ± 20 %	220 V DC ± 20 %	230 V AC/DC ± 20 %
max. input current per signal input	approx. 6 mA	approx. 4 mA	approx. 4 mA	approx. 4 mA	approx. 4 mA	approx. 4 mA	approx. 4 mA
Operating and ambient temperature without condensation	-20°C...+60°C	-20°C...+50°C	-20°C...+50°C	-20°C...+50°C	-20°C...+50°C	-20°C...+50°C	-20°C...+50°C

→ Technical data

Mechanical data	
Assembly	Panel mounting
Mounting position	arbitrary
Panel frame	96 x 96 mm
Required installation depth	80 mm
Panel cut out	91 x 91 +0.5 mm
Weight	0.5 kg
Connection terminals	cross section 1.5 mm ²

Ambient environment	
Storage temperature	-20 °C...+70 °C without condensation
Allowed relative humidity	max. 75 % (group F DIN 40040)
Type of protection front side	IP 40; IP 42 with window door; IP 65 with protection cover
Type of protection rear side	IP 20
Noise immunity	EMC-tested acc. to EN 61000-4-2,4,5

The information given for alternating voltages are referring to a sinusoidal alternating voltage with a frequency of 50/60 Hz and all information on an ambient temperature of 25°C, otherwise noted.

→ Terminal assignment

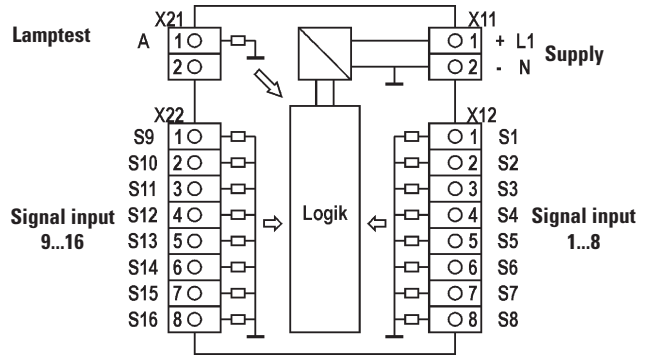
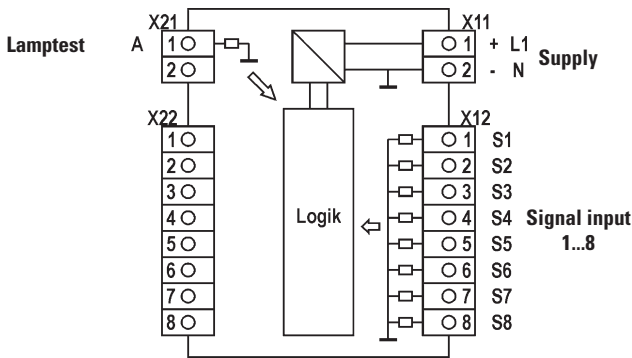

LAB 08-1

LAB 16-1

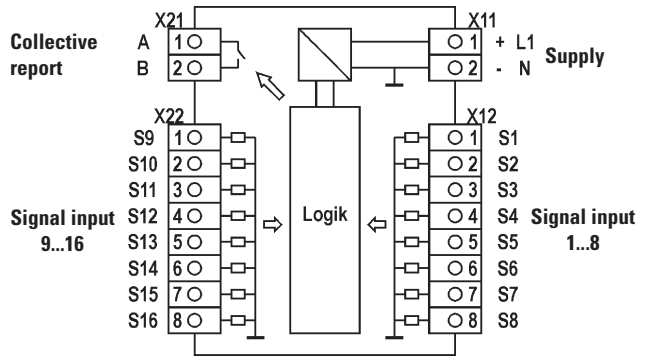
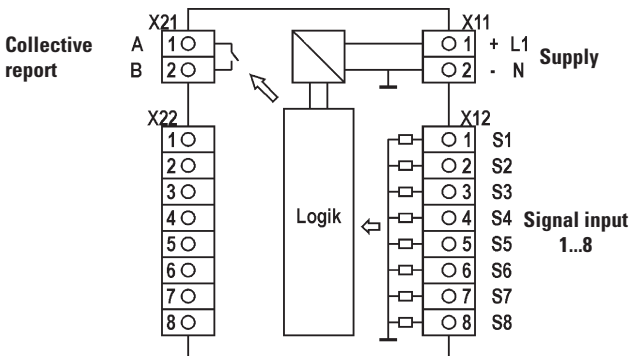

LAB 08-1M, LAB 08-1MR, LAB 08-1IMR

LAB 16-1M, LAB 16-1MR, LAB 16-1IMR



→ DIP-Switches in devices with collective report

After loosening the four screws and detaching the front plate DIP switches become visible. Each single report can be assigned to the integrated collective report by these DIP-switches.

With the switchgroup S1 the channels 1 ... 8 and with the switchgroup S2 the channels 9 ... 16 can be configured. If the switch is set to „ON“, the collective report will be triggered through the assigned input. At the LAB 08 variants only the DIP switch group S1 is existend.

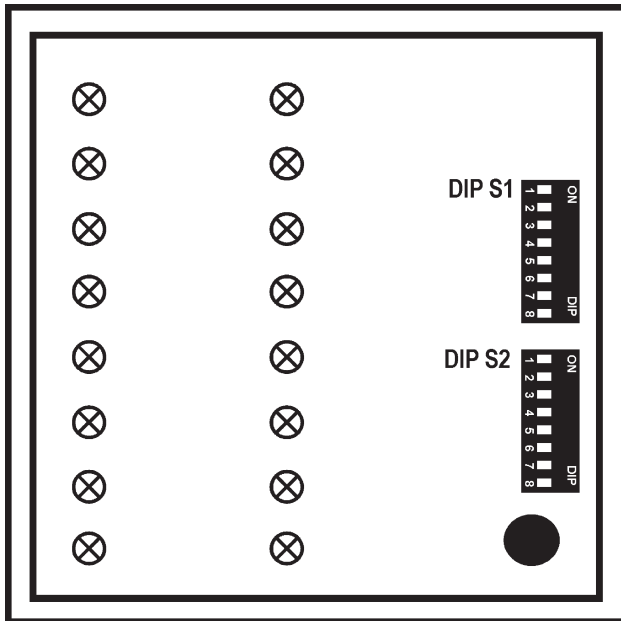

LAB 08-1M, LAB 16-1M

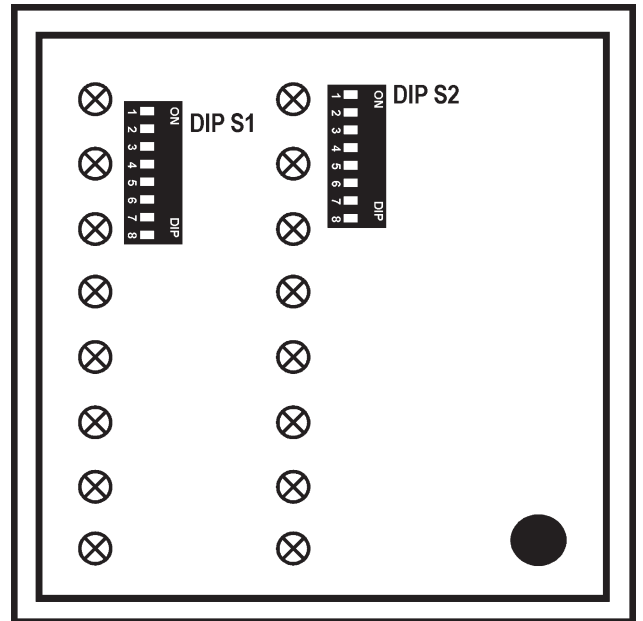

LAB 08-1MR, LAB 16-1MR,
LAB 08-11MR, LAB 16-11MR

→ Dimensional drawing

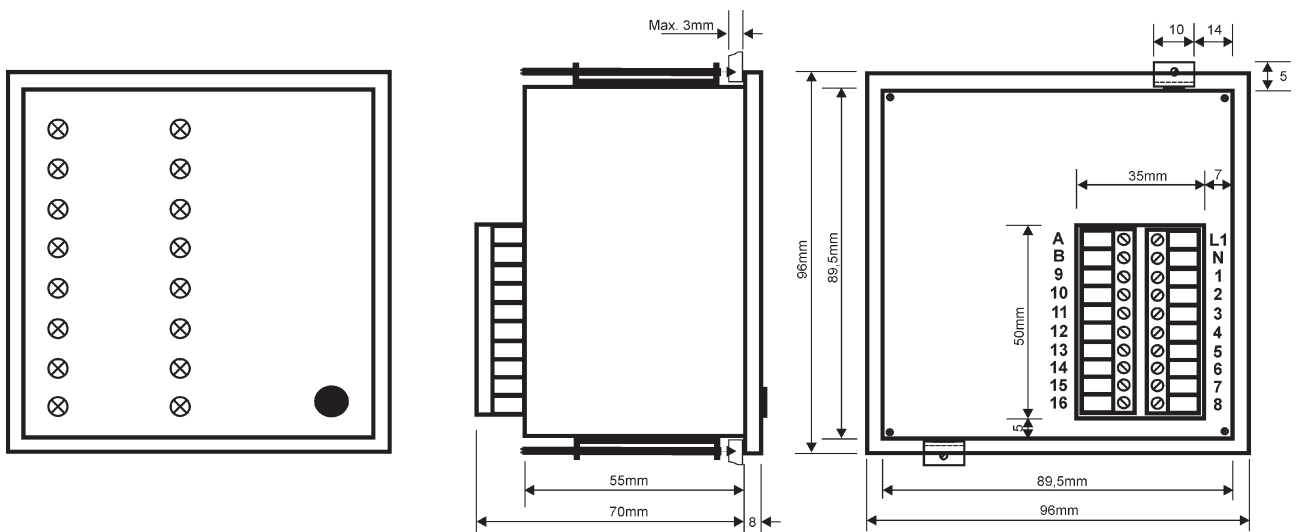

Dimension in mm
Subject to changes without prior notice

→ Accessories

21KST1	Clear window door (IP 42)
21KSH1	Protection cover (IP 65)
21BSV1	Labelling patterns (set of 10 patterns)
21BSV-Soft	Disc of labelling patterns for WinWord from Version 6.0 onwards
21LEDGELB	LED 5 mm yellow high efficiency
21LEDGRÜN	LED 5 mm green high efficiency
21LEDROT	LED 5 mm red high efficiency
21LEDWEISS	LED 5 mm white high efficiency

→ Do you need fault annunciators with fault storage?



BSM - Panel mounting basic fault annunciators

- Devices with 8, 16, 32 and 48 Signal inputs
- Sealed front, protection class IP 54
- Integrated buttons, functional inputs and relay outputs
- Self monitoring
- Optional DIN rail modules for PCS contacts
- Optional Software-Parameterisation via PC
- Realisation of all common alarm sequences
- Extremely bright LED with great reading angle and in many colours



FSM - Drop flaps fault annunciators

- Parameterisable compact fault annunciator for 10 alarms
- Signaling of stored reports also with voltage break down
- 10 neon yellow drop flaps and additionally green LEDs for permanent and dynamic status display
- Integrated buttons, functional inputs and relay outputs
- Live contact and nonvolatile eventmemory
- Supply and alarm signal voltage 12 V...250 V AC/DC
- 2 parameterisable collective reports and internal horn
- Parameterisation via DIP switches or PC programm
- Marker strips pocketable into transparent window